

## FREEDOM LIFTM8



### Technical Features:

- Light weight Aluminium frame weighing only 20kg- makes unit easy to handle and manoeuvre.
- The Freedom Lift M8 is available in two lift heights 800mm and 1000mm
- The winch is marine grade with “memory free” Kevlar rope
- Can lift up to 100kg
- Removable legs and folding forks makes the unit compact and easy to store.
- Tyres are filled with foam so that operation of the unit is smooth.
- Simple manual winch to operate the lift.
- Unit available with suction cups which are useful in applications where items such as Televisions, filing cabinets and glass panes are being handled.
- This unit is ideal for home deliveries etc as it is light, compact and easy to store

## Technical Specification:

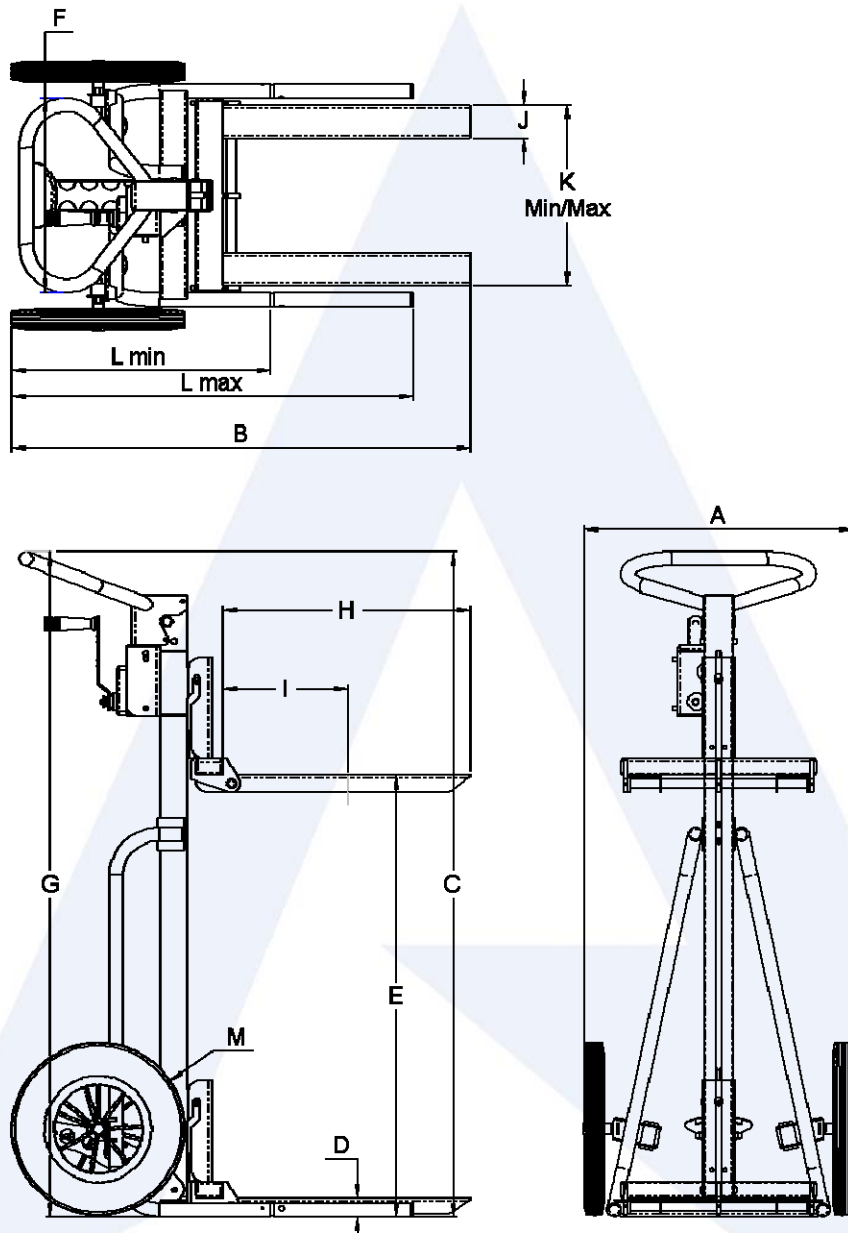

	A	B	C	D	E	F	G	H	I	J	K	L
	OVERALL WIDTH	OVERALL LENGTH	OVERALL HEIGHT	LOWERED HEIGHT	RAISED HEIGHT	HANDLE WIDTH	HANDLE HEIGHT	FORK LENGTH	LOAD CENTRE	FORK WIDTH	OVER FORKS min/max	LEG LENGTH
FORKS STD	500	880	1200	40	800	350	1200	440	220	60	130/330	470/730
FORKS TALL	500	880	1350	40	1000	350	1200	440	220	60	130/330	470/730
SUCTION CUP	500	480	1200	200*	950*	350	1200	n/a	n/a	n/a	n/a	n/a

All dimension are in mm unless otherwise shown